

# ONECOLLECTION

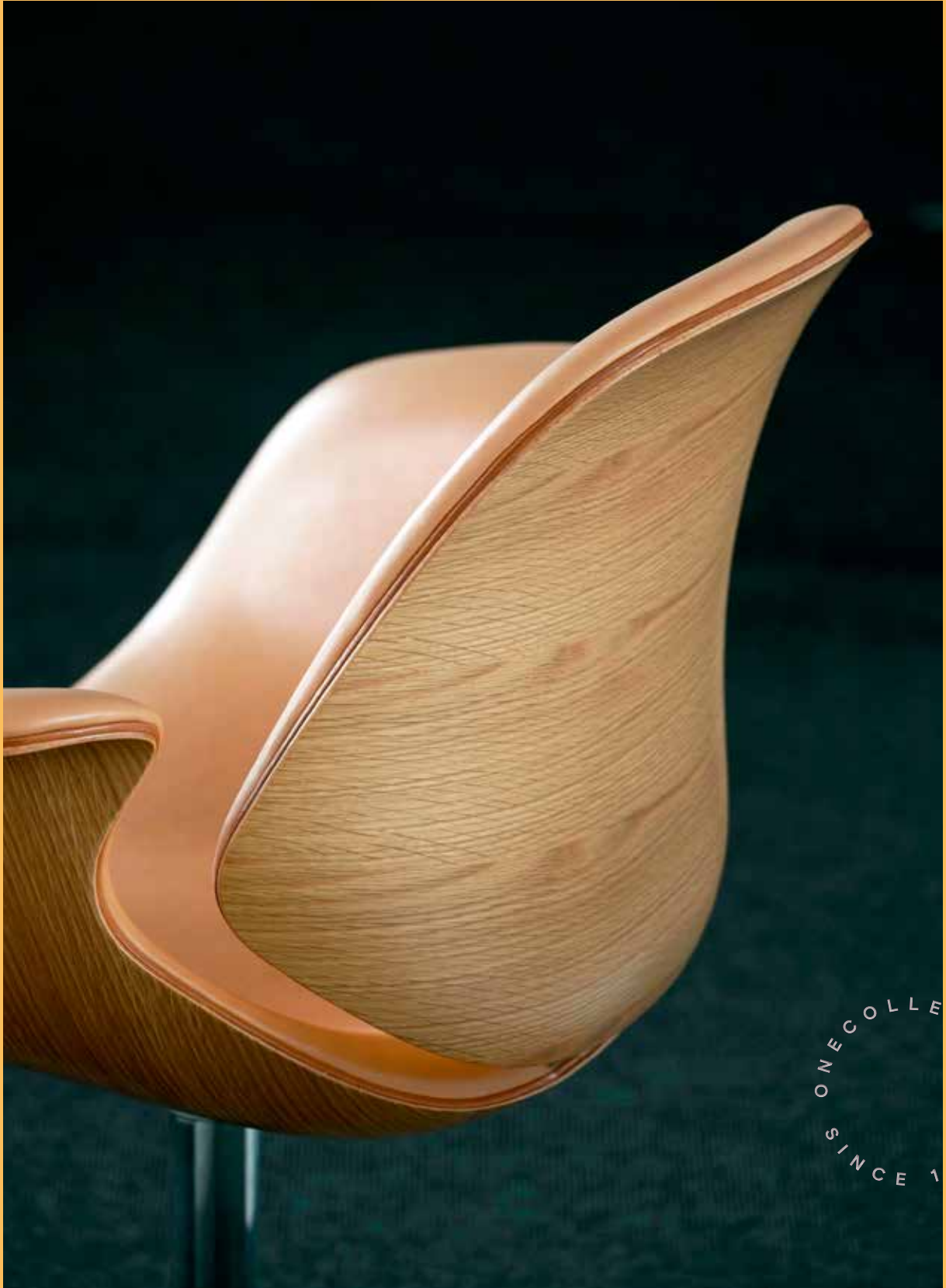

ONECOLLECTION  
SINCE 1990

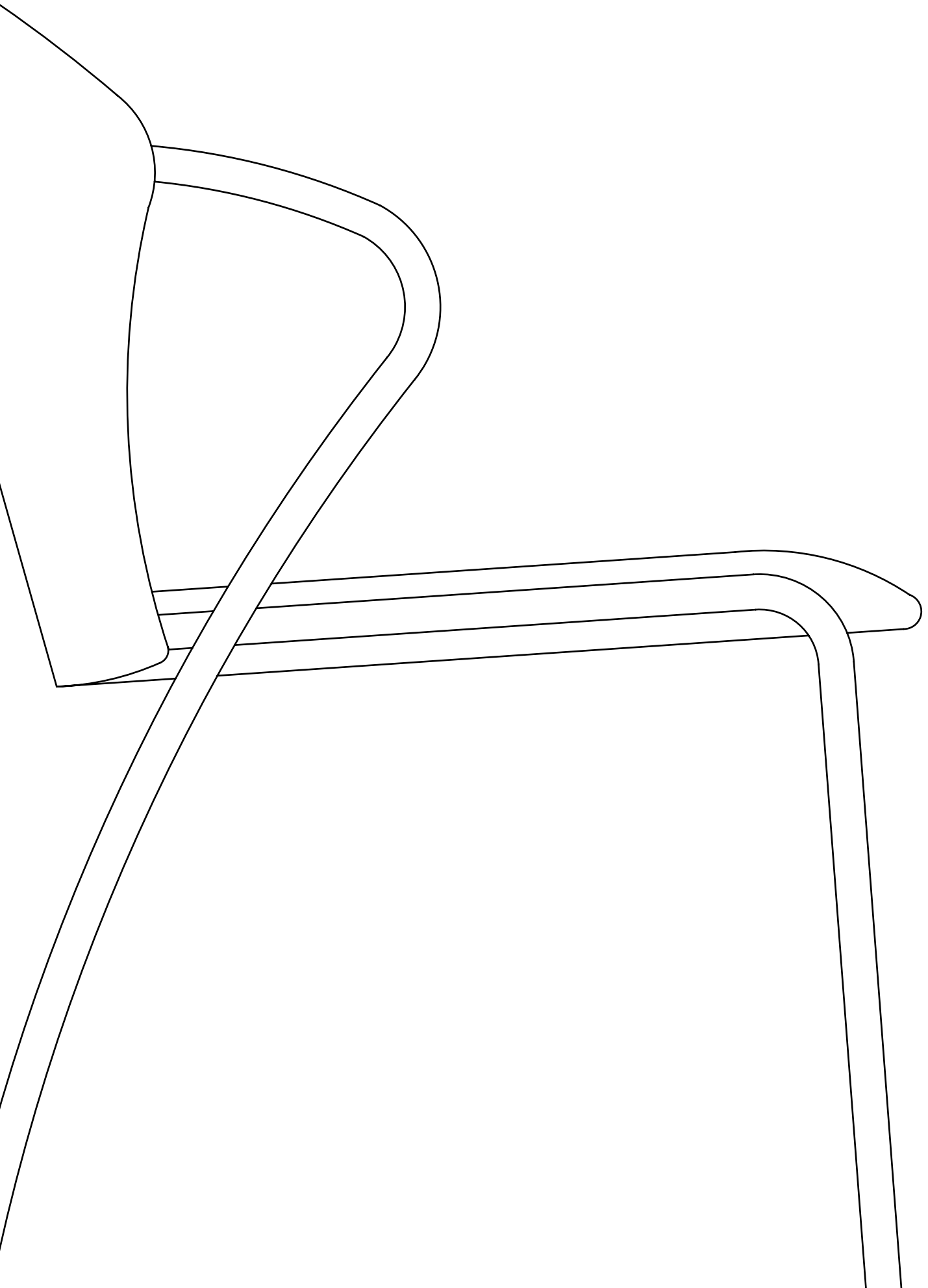

## ONECOLLECTION

Ever since the birth of Onecollection, our company has been rooted in the dialogue and collaboration with skilled designers, world-class architects and clients who demand the utmost in terms of quality and functionality.

Throughout our lifespan, Onecollection has completed countless of private as well as public projects, within the spheres of work environments, leisure, culture, education and trade.

When we embark on a new project, we always have one goal in mind. Namely to create high quality furniture and functional design, which will add significant value to any given environment.



Hans Henrik Sørensen



Ivan Hansen

ONECOLLECTION  
SINCE 1990



## COLLECTION

06	Council Chair
14	Council Lounge Chair
20	Council Table
26	Bessi Chair
32	Chairman Chair
36	Time Chair
44	Facon Table
46	Time Bar Stool
50	Time Stool
52	Ezone Desk & Meeting Tables
58	Train Table Series
60	Classic Bookcase
68	Dennie Chair, Stool and Table
72	Onecase
77	List of Locations and Photo Credits
78	Product Specifications

## COUNCIL CHAIR

**Kasper Salto and Thomas Sigsgaard**

The Council Chair was designed in 2011 by Kasper Salto and Thomas Sigsgaard for the Trusteeship Council Chamber at the U.N. Headquarters in New York.

The chair is well-thought out, shaped specifically with the human body in mind and made in form-pressed patented 3D veneer. Since the chair was designed for the 'secretaries table' in the Trusteeship Council Chamber it is crafted to ensure comfort throughout a long day.

Furthermore, the chair nicely complements good architecture, well-designed interiors and is thus ideal for the executive offices, VIP conference facilities, hotels and restaurants as well as private use for dining and working.

The chair is available in oak or walnut and is carefully upholstered in fabric or leather on a base of molded foam. The chair can also be ordered fully upholstered for a uniform expression. The elegant 4-star swivel base of the chair is cast aluminium with a polished finish.







Council Chairs at the Old Brewery Yard: New Carlsberg Foundation, Copenhagen









## TRUSTEESHIP COUNCIL CHAMBER

U.N. Headquarters, New York

Designers featured in this case:

Kasper Salto and Thomas Sigsgaard

In 2011, the design duo Salto & Sigsgaard won a design competition under the auspices of the Danish Ministry of Culture. The nature of the competition was to design new furniture for one of the permanent chambers at the Headquarters of the United Nations in New York, namely the Trusteeship Council Chamber. The function of the chamber has changed over the years and so has the number of member states. The beautiful chamber bears special significance in Danish design history, as it was donated by the Danish state and designed by the architect Finn Juhl in 1951. For this reason, it is also referred to as the Finn Juhl Chamber and is today regarded as the most important Danish national heritage alongside the Sydney Opera House.

Since Onecollection holds the sole legal rights to produce Finn Juhl furniture, Onecollection was, in order to maintain this national treasure, appointed to develop, produce and deliver the chamber's new furniture. This derived the birth of the unique Council Chair designed by Kasper Salto and Thomas Sigsgaard.

The chair passes on the baton from Finn Juhl's iconic design heritage in a sculptural and pleasant direction, that merges shape and natural materials into a single unit.



The Trusteeship Council Chamber - U.N. Headquarters, New York



## COUNCIL LOUNGE CHAIR

Kasper Salto and Thomas Sigsgaard

The Council Lounge Chair is a lower and slightly reclined version of the original Council Chair. The exciting backstory of the Council Chair is described on page 12.

The chair offers great seating comfort and is designed for lounge or reception areas as well as informal conferences.

The sculptural shape is made in form-pressed patented 3D veneer in oak or walnut with upholstery in fabric or leather. The chair can also be ordered fully upholstered. The swivel base of the chair is cast aluminium with a polished finish.







Council Lounge Chair at Gorrissen Federspiel, Axel Towers, Copenhagen





Council Lounge Chairs at Radiohuset, the former Headquarters of the Broadcasting Corporation DR, Copenhagen



Council Lounge Chairs at the Axel Towers, Copenhagen



## COUNCIL TABLE

**Kasper Salto and Thomas Sigsgaard**

The design duo Salto & Sigsgaard had their winning bid from the Trusteeship Council Chamber in mind when they designed an exclusive series of conference tables. The tables are designed to suit the Council Chair and the series is perfect for exclusive interior solutions.

The series is available with a tabletop in linoleum or veneered oak, walnut, teak or oregon pine with solid edges. The legs are cast aluminium with a polished finish. Furthermore, they are provided with a system for neatly managing cables. The tables come in three sizes with a rectangular or barrel shaped tabletop.

Customised sizes can be produced upon request.



Council Chairs and Table at The Danish Industry Foundation, Copenhagen







## OXFORD UNIVERSITY

**Oxford University Campus, Oxford**  
**Designers featured in this case:**  
**Kasper Salto and Thomas Sigsgaard**

When the distinguished Oxford University expanded their campus with the Blavatnik School of Government, Onecollection delivered the furniture for the executive offices, lounge and conference areas. Here, one will find Kasper Salto and Thomas Sigsgaard's Council Chair and Council Table as well as multiple sculptural Finn Juhl pieces. The organic shapes and natural materials speak to the building's excellent, transparent architecture, designed to encourage human interaction.

The Swiss architecture bureau Herzog & de Meuron designed the building, which is characterised by rows of slender glass. The glass panels, set into the faces of each of the curving volumes, are intended to echo the proportions of Oxford's Bodleian Library.

The building is defined by its different volumes providing scale and proportion. This style is chosen to complement the architectural heritage of Oxford University and reinterpret this in a contemporary context.







## BESSI CHAIR

Erla Sólveig Óskarsdóttir

Bessi is a light, stackable chair designed by the Icelandic designer Erla Sólveig Óskarsdóttir in 2000.

The compact, yet feather light, expression of Bessi unites minimalistic design and comfort. The frame offers an integrated armrest and connects the primary elements, ensuring durability and stability. With its all-around qualities, it is well-suited for numerous settings, private as well as public.

The shell of the Bessi Chair comes in either oak or walnut veneer or in black or white plastic. The chair can be delivered fully upholstered, with seat upholstery only, or without upholstery. Bessi can be upholstered in fabric or leather. The frame is available in chrome, satin chrome or painted steel in multiple colours.



2,500 Bessi Chairs at the United Nations Climate Change Conference at Bella Center, Copenhagen











## CHAIRMAN CHAIR

Henrik Tengler

The Chairman was designed by Henrik Tengler in 1990 for Onecollection and has since been produced exclusively in brushed stainless steel with a wooden backrest. The wooden backrest seamlessly conjoins with a stainless tube, which functions as an armrest and extends down to the floor.

Due to its adaptability, it has become a modern classic by setting the standards of today in terms of comfort for sleek quality design. To date, the Chairman has sold more than 60,000 units, making it the best-selling piece in the history of Onecollection.

The chair is available in solid oak, ash, walnut or teak with a veneered backside. The seat and the inside of the backrest are masterly upholstered with leather or fabric.

In 2015, Onecollection celebrated its 25th anniversary. To mark this special event, a new version of the best-selling Chairman was launched. The Chairman Anniversary Edition comes in a matt black painted steel frame with details in a raw brass finish.

The upholstery of the 2015 Anniversary Edition is identical to that of the original chair. This means that it is available with the seat and backrest upholstered in fabric or leather.











Chairman Chairs at the Royal Danish Opera House, Copenhagen

## TIME CHAIR

Henrik Tengler

The Time Chair is a dynamic and comfortable conference chair designed by Henrik Tengler in 2012. The chair is purposely designed not to follow current trends. Instead its aesthetic resembles the cosmopolitan functionalism of the Bauhaus period. Henrik Tengler has achieved this by incorporating an open steel frame and adding firm cushions.

The 12 mm steel tube construction of the chair ensures unbeatable strength in spite of the delicate expression of the chair. Furthermore, the oversized cushions create a titillating exchange between the carrying and carried elements of the chair. Lastly, time and effort has gone into shaping every detail of the chair, giving it a highly exclusive feel.

The chair allows for dynamic use and positions by responding to your movements. With clever features and ergonomic support, the Time Chair provides a high level of comfort throughout the day.

The chair is available with a four-star base and swivel or a five-star base with castors, gas lift, swivel and tilt. The frame comes in chrome or black painted steel with upholstery in fabric or leather.







Time Chairs at The Office Group, London







## SINO-DANISH CENTER

Sino-Danish Center, Beijing

Designers featured in this case: Kasper Salto and Thomas Sigsgaard, Henrik Tengler, Erla Sólveig Óskarsdóttir, Nanna & Jørgen Ditzel, Lars Frank Nielsen and Finn Juhl

In 2017 seven forty-foot containers filled with furniture were shipped from the West Coast of Denmark to Beijing, because Onecollection was appointed as the exclusive supplier for a new Danish/Chinese university in Beijing. The building was designed by Lundgaard and Tranberg Architects and since the building already portrayed Danish architecture it was only natural to choose Danish furniture for the interior.

The Danish Industry Foundation has supported the establishment of the Chinese building, which will serve as home to a research and educational collaboration between all eight Danish universities and the Chinese Academy of Science. The university is part of the government's strategy to foster knowledge-sharing between Denmark and China. The project is the largest Danish commitment within the areas of research and education ever to take place outside of Denmark.

The building's interior is planned by the Danish designer Henrik Tengler and carried out in close cooperation with Sino-Danish Center. To support the many different functions of a university, a wide selection of furniture from the collection was brought into the project. This included furniture designs from designers such as Kasper Salto and Thomas Sigsgaard, Henrik Tengler, Søren Ulrik Petersen, Nanna and Jørgen Ditzel, Lars Frank Nielsen and Erla Sólveig Óskarsdóttir.

For Onecollection, it has been of the utmost importance that the building in its entirety expresses and represents both Danish design and Danish values, such as transparency, openness and flexibility.





## FACON TABLE

Henrik Tengler

The Facon Table was designed by Henrik Tengler in 2014. It is characterised by having an asymmetric, rounded tabletop, which is wider in one end than in the other. This innovative egg-shape ensures an undisturbed view of any presentation at the wide end of the table, for everyone.

The characteristic shape also allows for a more dynamic interior, since the table can be placed freely in a room without a strict sense of direction.

The Facon Table is available in several sizes with a tabletop in linoleum, oak, ash, walnut or teak veneer. The base of the table consists of two three-star pedestals in a graphite powder coating or stainless steel.

Customised solutions can be produced upon request.





## TIME BAR STOOL

Henrik Tengler

The Time Bar Stool was designed by Henrik Tengler in 2015 as an addition to his popular Time series. The slender steel frame gives the chair a minimalist expression, while the round upholstered seat with the dot at the center, makes it fresh, modern and optionally colourful.

Despite a minimal look, the Time Bar Stool is both incredibly stable and strong which make the stool a natural fit for restaurants, bars and hotels. However, the Time Bar Stool also functions well in a dynamic workspace environment or at home at the kitchen counter.

The seat and button comes in fabric or leather and can be personalised by mixing materials and colours. The frame is available in chrome or black painted steel.

The Time Bar Stool is available in both counter - and bar height.











Time Bar Stools at the Sino-Danish Center for Education and Research, Beijing

## TIME STOOL

Henrik Tengler

The Time Stool is a dynamic height adjustable swivel stool on castors, suitable for multiple purposes. The stool was designed in 2017 by Henrik Tengler for the university project at Sino-Danish Center for Education and Research in Beijing. A major architectural project which was completely furnished by Onecollection.

Here the Time Stools offers a “seat on demand” in an open and dynamic workspace, with room for both group projects and individual work.

The functional swivel stool can be easily moved around and offers a fun and colourful addition to any informal dining, living, or working space.

The stool has a five-star base with castors, gas lift and swivel. It is available with a frame in chrome or black painted steel. The soft cushioned seat comes in fabric or leather. Just like its close relative, the Time Bar Stool, the center button can be customised.





Time Stools at the Sino-Danish Center for Education and Research, Beijing

## EZONE DESK & MEETING TABLES

Henrik Tengler

The Ezone Desk and Table Series were designed in 2004 by Henrik Tengler. Over the years Ezone has proven to be a reliable and durable companion in the daily lives of thousands of hard working people. Ezone has stood the test of time and has become the go-to-desk for many large corporations that refuse to compromise style, quality and functionality.

Ezone has become a true classic within height adjustable desks and tables. It combines a functional and minimalistic design with materials of the best quality and an impeccable attention to detail. This series includes a complete spectrum of meeting and work station tables that functionally and aesthetically live up to the highest standard of elegant and ergonomic solutions.

The electrically adjustable Ezone Table offers both flexibility and an advanced ergonomic performance in the workplace. In recent years, it has become a well-known fact that being able to move around throughout the day increases the well-being of the employee. Onecollection offers sit-to-stand solutions for the entire office, including open plan work stations and electrically height adjustable desks for private offices and conference rooms.

The Ezone is available with a tabletop in linoleum, laminate or veneered oak, ash walnut and teak. The T-foot pedestal legs come in stainless steel or graphite powder coating.

Ezone can be customised via numerous options, such as a foldable cable grommet in stainless steel, a hinged service carrier for managing cables, a pencil tray, a cabinet with drawers, a screen with a bulletin board and more.















## TRAIN TABLE SERIES

Henrik Tengler

The Train Table Series was designed by Henrik Tengler in 2004. The series is an all-inclusive elementary range, sit-to-stand solutions, with a myriad of possible combinations. In its simplicity, it caters to every need, from sofa table to conference table.

By choosing the Train Table series you can ensure a customised, streamlined style throughout the entire office, conference facility, hotel or restaurant.

The different combinable, elements are carefully crafted with sophisticated details, such as an organic shaped edge profile. The tabletop is available with linoleum, laminate or veneered teak, oak, ash or walnut. Different foot pedestal legs are available in powder coated steel or brushed stainless steel.

Customised solutions can be produced upon request.





## **CLASSIC BOOKCASE**

**Henrik Tengler**

Hide the mess while putting the most beloved items on display with Classic. The Classic Bookcase was designed by Henrik Tengler in 2015 and is an exclusive system with endless possibilities. The system offers elegant and flexible storage solutions for the private home or the office. Choose your preferred look by selecting and combining different types of woods and colours for the body and fronts. It is entirely up to you!

The Classic Bookcase System is only made to order. The veneer is selected and joined by our cabinet makers, so the grains of the wood line up perfectly, resulting in beautiful and unique pieces. Classic is available in oak, walnut, teak and oregon pine veneer with painted or veneered doors and drawer fronts, with solid brass handles.













Classic Bookcase, Time Chair and Ezone desk at the  
Sino-Danish Center for Education and Research, Beijing





## DENNIE CHAIR, STOOL AND TABLE

Nanna & Jørgen Ditzel

Onecollection has relaunched the easy chair, Dennie, which was designed by Nanna and Jørgen Ditzel in 1956 for Fritz Hansen. The Dennie Chair is nicely complemented by a footstool and a small table.

Nanna Ditzel, who was one of the most influential modern furniture designers in Denmark, passed away in 2005. Her daughter Dennie, who oversees her parents' design heritage, asked Onecollection to relaunch the chair which has always held a special place in her mother's house.

To Dennie, it is her cozy childhood chair, where she sat safely and had stories read out loud to her. The chair, symbolically named Dennie, is available with upholstery in fabric or leather and a frame in chrome or black painted steel.

The Dennie Chair combines style with casual comfort. Whether placed in the living room or the office, the curved shape and soft seat create a welcoming vibe that invoke relaxed conversations.

Furthermore, an upholstered footstool and a small side table with a white laminate tabletop are part of the Dennie series.







Dennie Chairs and Table at the Sino-Danish Center for Education and Research, Beijing

## ONECASE

Søren Ulrik Petersen

OneCase was designed by Søren Ulrik Petersen in 2010. OneCase is not a system - it is simply a single unit intended for storing, decoration, exhibition and fun. The case is based and constructed from the simple idea of cutting, folding and assembling a box.

OneCase has a light expression, obtained by the white lacquered 4 mm Alu-Dibond board processed in a modern CNC machine. The unique material composition of OneCase makes it incredibly strong and ideal for the paper thin design. The standard back panel is black, however, easily changeable and comes in a variety of strong high gloss colours.

Customise OneCase by changing the colours according to your mood, a special occasion or the season and highlight your most important belongings against a fun and colourful background. There is only one module in the series, but 8 different colour options. OneCase is intended for wall mounting or for putting on a plinth.













## LIST OF LOCATIONS AND PHOTO CREDITS

- Gorrissen Federspiel, Axel Towers, Copenhagen (P. 10-11 + 16 + 18-19)  
The Danish Industry Foundation, Copenhagen (P. 20 + 21)  
The Office Group, London (P. 38 + 39)  
The Old Brewery Yard: New Carlsberg Foundation, Copenhagen (P. 8 + 9)  
Oxford University Campus, Oxford (P. 24 + 25)  
Radiohuset, the former Headquarters of the Broadcasting Corporation DR,  
Copenhagen, Kasper Salto and Thomas Sigsgaard (P. 17 + 76)  
The Royal Danish Opera, Copenhagen - Photographer: Christian Møller Andersen,  
Sorensen Leather (P. 33 + 34 + 35)  
The Sino-Danish Center for Education and Research, Beijing  
(P. 28 + 42 + 43 + 48 + 49 + 50 + 51 + 59 + 66-67 + 70)  
The Trusteeship Council Chamber - U.N. Headquarters, New York (P. 12 + 13)

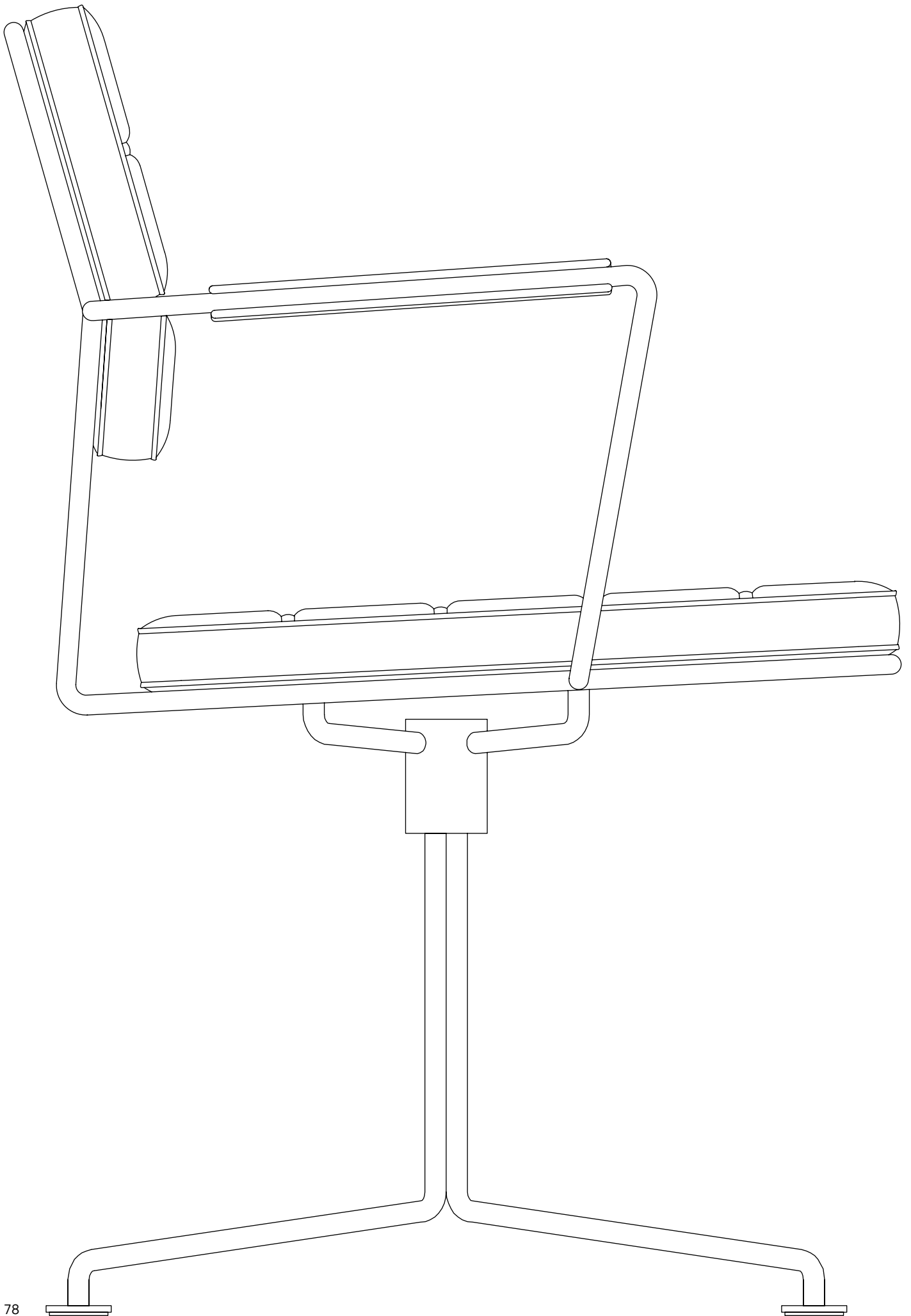

## **PRODUCT SPECIFICATIONS**

## COUNCIL CHAIR

---

**YEAR** 2011

**MATERIALS** **KT 8013**  
Seat and back: 3D veneer, oak or walnut  
w/ upholstery inside  
Legs: Cast or polished  
aluminium incl. swivel  
Upholstery: Fabric or leather

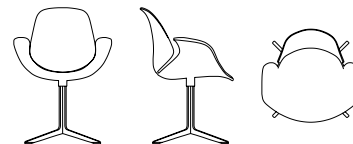

**KT 8014 (fully upholstered)**  
Seat and back: 3D veneer  
fully upholstered  
Legs: Cast or polished  
aluminium incl. swivel  
Upholstery: Fabric or leather

**DIMENSIONS**  
W: 66 cm  
D: 60 cm  
H: 85 cm  
Sh: 47 cm  
Weight: 9 kg  
Cbm: 0.44 m<sup>3</sup>

## COUNCIL LOUNGE CHAIR

---

**YEAR** 2011

**MATERIALS** **KT 8023**  
Seat and back: 3D veneer  
w/ upholstery inside  
Legs: Cast, polished  
aluminium incl. swivel  
Upholstery: Fabric or leather

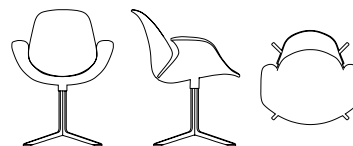

**KT 8024 (fully upholstered)**  
Seat and back: 3D veneer  
Fully upholstered  
Legs: Cast, polished  
aluminium incl. swivel  
Upholstery: Fabric or leather

**DIMENSIONS**  
W: 66 cm  
D: 60 cm  
H: 76 cm  
Sh: 43 cm  
Weight: 9 kg  
Cbm: 0.44 m<sup>3</sup>



## COUNCIL TABLE

---

YEAR

2011

MATERIALS

Legs: Polished aluminium  
Tabletop: Oak, ash, walnut, teak veneer or  
linoleum w/ solid edges

DIMENSIONS

**KT 8324**

L: 240 cm

W: 110 cm

H: 72 cm

Weight: 63 kg

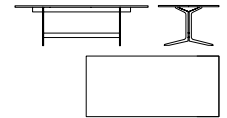

**KT 8331 (tabletop in two parts)**

L: 310 cm

W: 110 cm

H: 72 cm

Weight: 77 kg

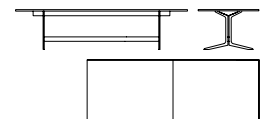

**KT 8338 (tabletop in two parts)**

L: 380 cm

W: 110 cm

H: 72 cm

Weight: 92 kg

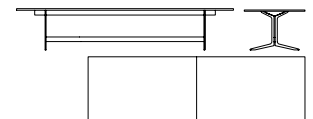

**KT 8424**

L: 240 cm

W: 110 cm

H: 72 cm

Weight: 63 kg

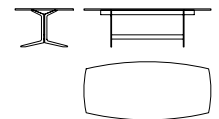

**KT 8431 (tabletop in two parts)**

L: 310 cm

W: 110 cm

H: 72 cm

Weight: 77 kg

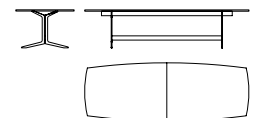

**KT 8438 (tabletop in two parts)**

L: 380 cm

W: 110 cm

H: 72 cm

Weight: 92 kg

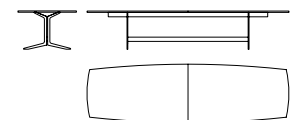

## BESSI CHAIR

---

<b>YEAR</b>	2000
<b>MATERIALS</b>	<p><b>EO 5400 (stackable)</b> Frame: Chrome, satin chrome or black painted Back and seat: Black or white plastic</p> <p><b>EO 5401 (w/seat upholstery)</b> Frame: Chrome, satin chrome or black painted Back: Black or white plastic, oak, walnut Seat: Fabric or leather</p> <p><b>EO 5402 (fully upholstered)</b> Frame: Chrome, satin chrome or black painted Upholstery: Fabric or leather</p>
<b>DIMENSIONS</b>	W: 55 cm D: 57 cm H: 80 cm Sh: 45 cm Weight: 5 kg Cbm: 0.37 m <sup>3</sup> /3 pcs.
<b>ACCESSORIES</b>	<p><b>EO 5455</b> Line up Bessi chairs by linking them together with this linking device in Chrome.</p>

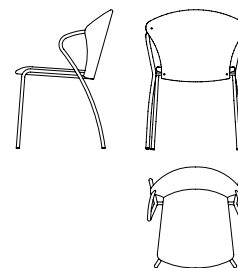

## CHAIRMAN

---

<b>YEAR</b>	1990
<b>MODEL AND MATERIALS</b>	<p><b>HT 6101</b> Frame: Brushed stainless steel w/back piece in oak, ash, walnut or teak Upholstery: Fabric or leather</p> <p><b>HT 6110 (anniversary model)</b> Frame: Mat black and brass w/back piece in oak, ash, walnut or teak Upholstery: Fabric or leather</p>
<b>DIMENSIONS</b>	W: 55 cm D: 50 cm H: 76 cm Sh: 45 cm Weight: 6 kg Cbm: 0.33 m <sup>3</sup> /2 pcs.

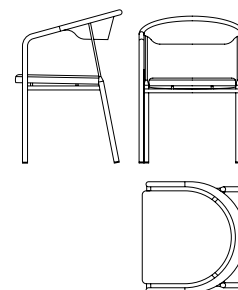

## TIME CHAIR

---

<b>YEAR</b>	2014
<b>MODEL</b>	<b>HT 2012</b>
<b>MATERIALS</b>	Chrome or black painted, 4-star frame with feet, incl. swivel. Upholstery: Fabric or leather
<b>DIMENSIONS</b>	W: 57 cm D: 55 cm H: 80 cm Sh: 46 cm Weight: 15 kg Cbm: 0.28 m <sup>3</sup>



## TIME CHAIR

---

<b>YEAR</b>	2014
<b>MODEL</b>	<b>HT 2014</b>
<b>MATERIALS</b>	Chrome or black painted, 5-star frame with castors, incl. gas lift, swivel and tilt Upholstery: Fabric or leather
<b>DIMENSIONS</b>	W: 57 cm D: 55 cm H: 80 cm Sh: 42-53 cm Weight: 15 kg Cbm: 0.28 m <sup>3</sup>

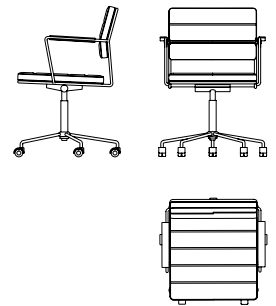

## FACON TABLE

**YEAR** 2014

**MATERIALS** Feet: 2 pedestal legs, 3-star  
Tabletop in linoleum or veneered oak, ash, walnut or teak with Train mouldings

**MODEL AND DIMENSIONS**

**HT 4318**  
L: 180 cm  
W: 90/75 cm  
H: 71.4 cm  
Weight: 73 kg

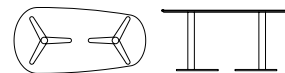

**HT 4320**  
L: 200 cm  
W: 100/80 cm  
H: 71.4 cm  
Weight: 81 kg

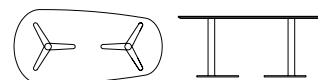

**HT 4322**  
L: 220 cm  
W: 110/87 cm  
H: 71.4 cm  
Weight: 92 kg

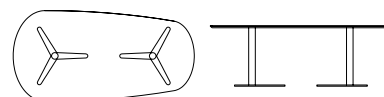

**HT 4324**  
L: 240 cm  
W: 120/96 cm  
H: 71.4 cm  
Weight: 101 kg

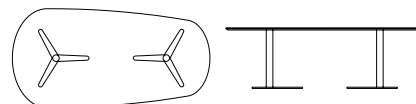

**PEDESTAL LEGS**

**Small 3-star**  
HT 4371MM - H: 71 cm (painted)  
HT 4371SS - H: 71 cm (stainless steel)

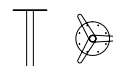

**Large 3-star**  
HT 4372MM - H: 71 cm (painted)  
HT 4372SS - H: 71 cm (stainless steel)

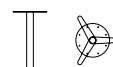

**Leg**  
HT 4373MM - H: 71 cm (painted)  
HT 4373SS - H: 71 cm (stainless steel)

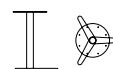

## TIME BAR STOOL

---

**YEAR** 2015

**MATERIALS** Legs: Chrome or black painted  
Upholstered seat w/ button in fabric or leather

**MODEL AND DIMENSIONS** **HT 2266 (small)**  
W: 36 cm  
D: 36 cm  
H: 65.5 cm  
Sh: 65.5 cm  
Weight: 5 kg  
Cbm: 0.12 m<sup>3</sup>

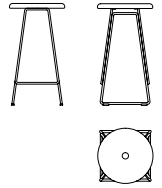

**HT 2288 (large)**  
W: 36 cm  
D: 36 cm  
H: 75 cm  
Sh: 75 cm  
Weight: 5.5 kg  
Cbm: 0.12 m<sup>3</sup>

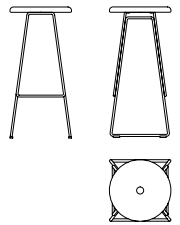

## TIME STOOL

---

**YEAR** 2017

**MODEL** **HT 2244**

**MATERIALS** Stool with a 5-star frame w/ castors, gas lift and swivel.  
Frame: Chrome or black painted  
Upholstered seat w/ button in fabric or leather

**DIMENSIONS** W: 36 cm  
D: 36 cm  
H: 44-56.5 cm  
Sh: 44-56.5 cm  
Weight: 5 kg  
Cbm: 0.10 m<sup>3</sup>

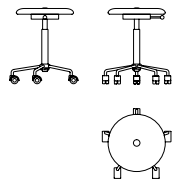

# EZONE MEETING TABLE

**YEAR** 2005

**MATERIALS** All tables are complete with T-foot pedestals, service carrier and cable shutter in stainless steel.

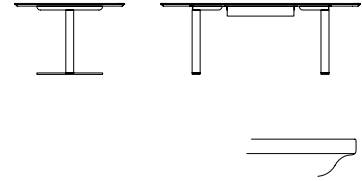

Graphite powder coating. Extra charge for electric height adjustment and round pedestal feet, see below.

Tabletop: Oak, walnut, ash, teak, laminate or linoleum

**MODEL AND DIMENSIONS**

**Tabletop w/2 pedestal legs w/T-foot**

- OC 2018 R/O - 180 cm x 90 cm
- OC 2020 R/B - 200 cm x 90 cm
- OC 2022 R/B - 220 cm x 90 cm
- OC 2120 R/B - 200 cm x 110 cm
- OC 2220 R/B/O - 200 cm x 128 cm
- OC 2122 R/B - 220 cm x 110 cm
- OC 2222 R/B - 220 cm x 128 cm
- OC 2124 R/B - 240 cm x 110 cm
- OC 2224 R/B - 240 cm x 128 cm
- OC 2126 R/B - 260 cm x 110 cm
- OC 2226 R/B/O - 260 cm x 128 cm

R = Rectangular



B = Curved



O = Oval

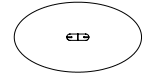

**Tabletop in 2 parts w/3 pedestal legs w/T-foot**

- OC 2130 R/B - 300 x 110 cm
- OC 2230 R/B - 300 x 128 cm
- OC 2136 R/B - 360 x 110 cm
- OC 2236 R/B - 360 x 128 cm
- OC 2140 R/B - 400 x 110 cm
- OC 2240 R/B - 400 x 128 cm

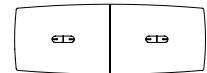

**Tabletop in 3 parts w/4 pedestal legs w/T-foot**

- OC 2149 R/B - 490 x 110 cm
- OC 2249 R/B - 490 x 128 cm
- OC 2155 R/B - 550 x 110 cm
- OC 2255 R/B - 550 x 128 cm

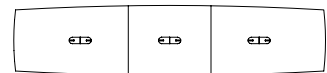
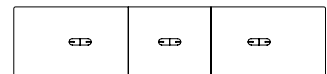

**Tabletop in 4 parts w/5 pedestal legs w/T-foot**

- OC 2162 R/B - 620 x 110 cm
- OC 2262 R/B - 620 x 128 cm
- OC 2170 R/B - 700 x 110 cm
- OC 2270 R/B - 700 x 128 cm

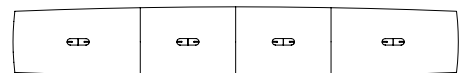

**Round Pedestal foot**

- OC 2657 M - Ø 50 cm (painted)
- OC 2657 S - Ø 50 cm (stainless steel)
- OC 2667 M - Ø 60 cm (painted)
- OC 2667 S - Ø 60 cm (stainless steel)
- OC 2677 M - Ø 70 cm (painted)
- OC 2677 S - Ø 70 cm (stainless steel)

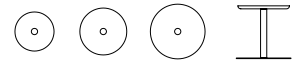

**ACCESSORIES**

**Electric adjustable pedestal foot**

- Linak DL 11
- OC 2311 H - 62-127 cm

**Foldable cable shutter**

- OC 1270 - 35 x 10 cm

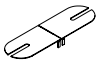

**Service carrier**

- OC 1245 - 70 cm

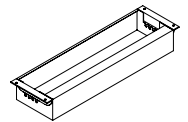

**EZONE DESK**

---

**YEAR**

2005

**MATERIALS**

Electric height adjustable desk, 63-127 cm  
Incl. two Ø 70 mm cable grommets in stainless steel.

Tabletop in oak, walnut, ash, teak, laminate or linoleum. Frame in stainless steel or painted

For special sizes, please inquire for offer

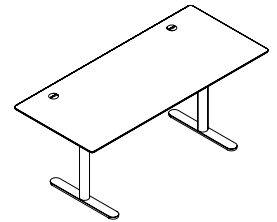

**MODEL AND DIMENSIONS**

- OC 1001 - 80 x 160 cm
- OC 1002 - 80 x 180 cm
- OC 1003 - 90 x 180 cm
- OC 1004 - 90 x 200 cm
- OC 1005 - 100 x 180 cm
- OC 1006 - 100 x 200 cm

**ACCESSORIES**

**Front panel**

Available in veneer, painted or sat. acrylic (8 mm)

Incl. holders in stainless steel

- OC 1220 - 40 x 150 cm
- OC 1221 - 40 x 170 cm
- OC 1222 - 40 x 190 cm
- OC 1226 - 40 x 70 cm
- OC 1227 - 40 x 80 cm
- OC 1228 - 40 x 90 cm

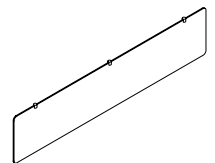

## ACCESSORIES

### Service carrier

Hinged for downfolding  
Graphite powder coating

**OC 1240** - 127 cm

**OC 1245** - 70 cm

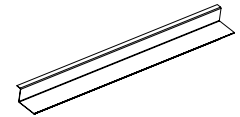
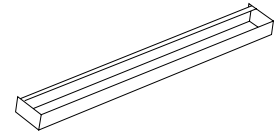

### Cable tray

Graphite powder coating

**OC 1250** - 120 cm

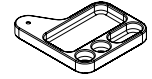

### Turnable Pencil Tray

Black soft coat

**OC 1260**

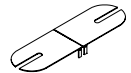

### Tiltable cable shutter

Stainless steel

**OC 1270**

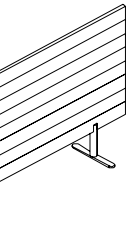

### Screen with bulletin board

With feet in graphite powder coating or stainless steel

**OC 1280** - 180 x 126 cm

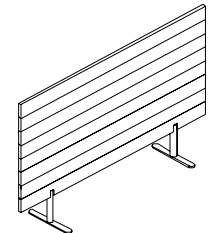

### Cabinet with drawers

Black painted MDF

Top drawer is a pencil tray

**OC 1301**

W: 45 cm

D: 60 cm

H: 56.5 cm

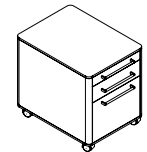

### Cabinet accessories

**OC 1310** - Central locking

**OC 1311** - Suspension filing drawer

**OC 1312** - Form holder, 10 pcs.

**OC 1313** - drawer divider



## TRAIN TABLE SERIES

---

**YEAR** 2011

**MATERIALS** Tabletop in oak, walnut, ash, teak, laminate or linoleum

**MODEL AND DIMENSIONS**

**Circular tabletop**

HT 9001 - Ø 65 cm  
HT 9101 - Ø 80 cm  
HT 9201 - Ø 90 cm  
HT 9301 - Ø 110 cm  
HT 9401 - Ø 130 cm

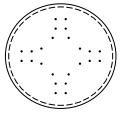

**Half-round tabletop**

HT 9002 - 1/2 Ø 65 cm  
HT 9102 - 1/2 Ø 80 cm  
HT 9202 - 1/2 Ø 90 cm  
HT 9302 - 1/2 Ø 110 cm  
HT 9402 - 1/2 Ø 130 cm



**Square tabletop**

HT 9010 - 65 x 65 cm  
HT 9110 - 80 x 80 cm  
HT 9210 - 90 x 90 cm  
HT 9310 - 110 x 110 cm  
HT 9410 - 130 x 130 cm

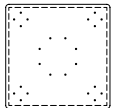

**Rectangular tabletop**

HT 9013 - 65 X 130 cm  
HT 9015 - 65 X 150 cm  
HT 9113 - 80 X 130 cm  
HT 9115 - 80 x 150 cm  
HT 9118 - 80 x 180 cm  
HT 9213 - 90 X 130 cm  
HT 9215 - 90 x 150 cm  
HT 9218 - 90 x 180 cm  
HT 9315 - 110 x 150 cm  
HT 9318 - 110 x 180 cm  
HT 9319 - 110 x 200 cm  
HT 9415 - 130 x 150 cm  
HT 9419 - 130 x 200 cm



### Tabletop for endings

- HT 9020 - 65 x 65 cm
- HT 9023 - 65 x 130 cm
- HT 9025 - 65 x 150 cm
- HT 9120 - 80 x 80 cm
- HT 9123 - 80 x 130 cm
- HT 9125 - 80 x 150 cm
- HT 9220 - 90 x 90 cm
- HT 9223 - 90 x 130 cm
- HT 9225 - 90 x 150 cm
- HT 9228 - 90 x 180 cm
- HT 9323 - 110 x 130 cm
- HT 9325 - 110 x 150 cm
- HT 9328 - 110 x 180 cm
- HT 9420 - 130 x 130 cm
- HT 9425 - 130 x 150 cm
- HT 9429 - 130 x 200 cm

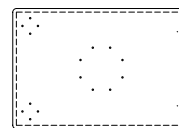

### Middle plate tabletop

- HT 9030 - 65 x 65 cm
- HT 9033 - 65 x 130 cm
- HT 9035 - 65 x 150 cm
- HT 9131 - 80 x 65 cm
- HT 9133 - 80 x 130 cm
- HT 9135 - 80 x 150 cm
- HT 9231 - 90 x 65 cm
- HT 9233 - 90 x 130 cm
- HT 9235 - 90 x 150 cm
- HT 9331 - 110 x 65 cm
- HT 9333 - 110 x 130 cm
- HT 9335 - 110 x 150 cm
- HT 9431 - 130 x 65 cm
- HT 9433 - 130 x 130 cm
- HT 9435 - 130 x 150 cm

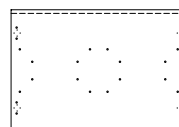

### Curved tabletop

- HT 9060 - 65 x 65 cm
- HT 9160 - 80 x 80 cm
- HT 9260 - 90 x 90 cm
- HT 9265 - 90 x 150 cm
- HT 9360 - 110 x 100 cm
- HT 9365 - 110 x 165 cm
- HT 9368 - 110 x 180 cm
- HT 9369 - 110 x 200 cm
- HT 9460 - 130 x 130 cm
- HT 9469 - 130 x 200 cm

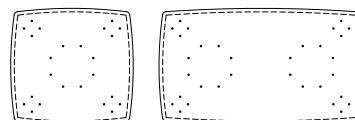

**Curved tabletop for endings**

- HT 9351 - 110 x 110 cm
- HT 9353 - 110 x 130 cm
- HT 9453 - 130 x 130 cm
- HT 9355 - 110 x 150 cm
- HT 9358 - 110 x 180 cm
- HT 9455 - 130 x 150 cm
- HT 9459 - 130 x 200 cm

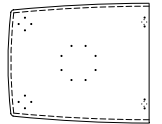

**TRAIN LEGS**

**Painted pedestal foot**

- HT 9654MM - H 51 cm x Ø 50 cm
- HT 9664MM - H 51 cm x Ø 60 cm
- HT 9674MM - H 51 cm x Ø 70 cm



- HT 9657MM - H 71 cm x Ø 50 cm
- HT 9667MM - H 71 cm x Ø 60 cm
- HT 9677MM - H 71 cm x Ø 70 cm

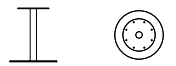

- HT 9659MM - H 100 cm x Ø 50 cm
- HT 9669MM - H 100 cm x Ø 60 cm
- HT 9679MM - H 100 cm x Ø 70 cm

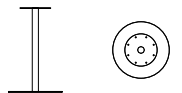

**Pedestal foot in stainless steel**

- HT 9654SS - H 51 cm x Ø 50 cm
- HT 9664SS - H 51 cm x Ø 60 cm
- HT 9674SS - H 51 cm x Ø 70 cm



- HT 9657SS - H 71 cm x Ø 50 cm
- HT 9667SS - H 71 cm x Ø 60 cm
- HT 9677SS - H 71 cm x Ø 70 cm

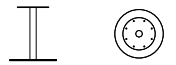

- HT 9659SS - H 100 cm x Ø 50 cm
- HT 9669SS - H 100 cm x Ø 60 cm
- HT 9679SS - H 100 cm x Ø 70 cm

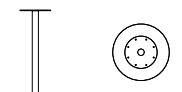

**Painted t-foot**

- HT 9668MM - H 71 cm x Ø 50 cm



**T-foot in stainless steel**

- HT 9668SS - H 71 cm x Ø 50 cm



**Legs in chrome or satin chrome**

- HT 9604 SC - H 42 cm
- HT 9607 SC - H 71 cm
- HT 9605 BC - H 42 cm
- HT 9608 BC - H 71 cm



**Leg in solid wood (oak or walnut)**

- HT 9617 - H 71 cm



**Recommended foot sizes for Train  
pedestal legs**

Width 65-80 cm - Foot Ø 50 cm

Width 90-110 cm - Foot Ø 60 cm

Width 130 cm - Foot Ø 70 cm

Regarding table sizes above L 180 cm,  
we recommend pedestal feet instead  
of table legs because of increased  
stability.

Tables longer than L 130 cm, with  
legs, will be delivered with a table-  
top support in steel.

**CLASSIC BOOKCASE**

---

**YEAR** 2017

**MATERIALS** Shelf unit in oak, walnut, Oregon  
pine or teak veneer

**MODEL AND  
DIMENSIONS**

**HT 8420**

W: 41.75 cm

D: 36.5 cm

H: 20.5 cm

Weight: 9 kg

Cbm: 0.06 m<sup>3</sup>



**HT 8820**

W: 80 cm

D: 36.5 cm

H: 20.5 cm

Weight: 13 kg

Cbm: 0.11 m<sup>3</sup>



**HT 8821**

W: 80 cm

D: 36.5 cm

H: 20.5 cm

Weight: 19 kg

Cbm: 0.11 m<sup>3</sup>



**HT 8430**

W: 41.75 cm

D: 36.5 cm

H: 37.5 cm

Weight: 13 kg

Cbm: 0.10 m<sup>3</sup>



**HT 8433**

W: 41.75 cm  
D: 36.5 cm  
H: 37.5 cm  
Weight: 12 kg  
Cbm: 0.10 m<sup>3</sup>



**HT 8434**

W: 41.75 cm  
D: 36.5 cm  
H: 37.5 cm  
Weight: 12 kg  
Cbm: 0.10 m<sup>3</sup>



**HT 8830**

W: 80 cm  
D: 36.5 cm  
H: 37.5 cm  
Weight: 22 kg  
Cbm: 0.18 m<sup>3</sup>



**HT 8831**

W: 80 cm  
D: 36.5 cm  
H: 37.5 cm  
Weight: 28 kg  
Cbm: 0.18 m<sup>3</sup>

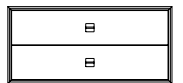

**HT 8832**

W: 80 cm  
D: 36.5 cm  
H: 37.5 cm  
Weight: 14 kg  
Cbm: 0.11 m<sup>3</sup>

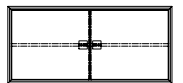

**HT 8470**

W: 41.75 cm  
D: 36.5 cm  
H: 73 cm  
Weight: 18 kg  
Cbm: 0.18 m<sup>3</sup>

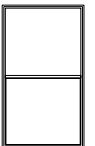

**HT 8473**

W: 41.75 cm  
D: 36.5 cm  
H: 73 cm  
Weight: 21 kg  
Cbm: 0.18 m<sup>3</sup>

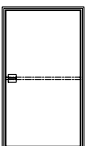

**HT 8474**

W: 41.75 cm  
D: 36.5 cm  
H: 73 cm  
Weight: 21 kg  
Cbm: 0.18 m<sup>3</sup>



**HT 8870**

W: 80 cm  
D: 36.5 cm  
H: 73 cm  
Weight: 31 kg  
Cbm: 0.32 m<sup>3</sup>

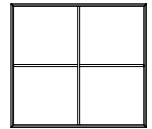

**HT 8871**

W: 80 cm  
D: 36.5 cm  
H: 73 cm  
Weight: 47 kg  
Cbm: 0.32 m<sup>3</sup>

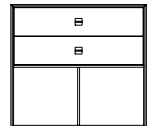

**HT 8872**

W: 80 cm  
D: 36.5 cm  
H: 73 cm  
Weight: 37 kg  
Cbm: 0.32 m<sup>3</sup>

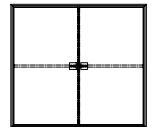

**ACCESSORIES**

**Wall mounting**

**HT 8801**

**Small base**

**HT 8402**

W: 41.75 cm  
D: 36.5 cm  
H: 80 cm

**Large base**

**HT 8802**

W: 80 cm  
D: 36.5 cm  
H: 80 cm

**Legs**

**HT 8803**

One set of 4 legs in solid wood

**Extra shelf**

**HT 8804**

W: 41.75 cm  
D: 36.5 cm  
H: 80 cm

## DENNIE CHAIR

---

<b>YEAR</b>	1956
<b>MODEL</b>	<b>NJ 2056</b>
<b>MATERIALS</b>	Frame: Satin chrome, chrome, burnished steel or black painted Upholstery: Fabric or leather
<b>DIMENSIONS</b>	W: 82 cm D: 80 cm H: 90 cm Sh: 37 cm Weight: 13 kg Cbm: 0.68 m <sup>3</sup>

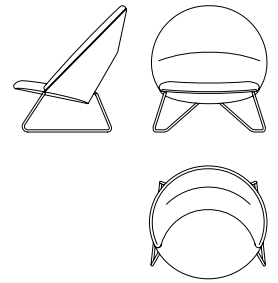

## DENNIE FOOTSTOOL

---

<b>YEAR</b>	1956
<b>MODEL</b>	<b>NJ 2057</b>
<b>MATERIALS</b>	Frame: Satin chrome, chrome, burnished steel or black painted Upholstery: Fabric or leather
<b>DIMENSIONS</b>	W: 40 cm D: 40 cm H: 35 cm Weight: 3 kg Cbm: 0.06 m <sup>3</sup>

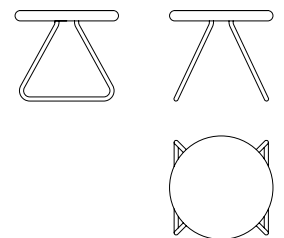

## DENNIE TABLE

---

<b>YEAR</b>	1956
<b>MODEL</b>	<b>NJ 2058</b>
<b>MATERIALS</b>	Frame: Satin chrome, chrome, burnished steel or black painted
<b>DIMENSIONS</b>	Ø: 55 cm H: 34 cm Weight: 5 kg Cbm: 0.13 m <sup>3</sup>

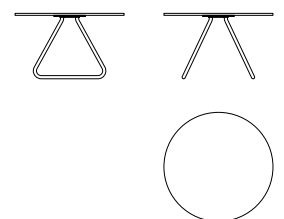

## ONECASE

---

**YEAR** 2010

**MODEL** **SU 1000**

**MATERIALS** White Alu-Dibond incl. wall mounting

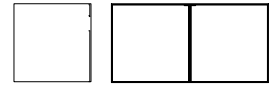

**DIMENSIONS**

W: 66 cm  
D: 33 cm  
H: 33 cm  
Weight: 3 kg  
Cbm: 0.11 m<sup>3</sup>

**Onecase back cover**

**SU 1001**

3 mm high gloss melamine in blue/  
green, white/yellow, red/orange or  
black/grey



**Onecase plinth**

**SU 1002**

Stainless steel or painted white

W: 66 cm  
D: 29 cm  
H: 13 cm









Onecollection A/S  
Vesterled 19  
DK-6950 Ringkøbing  
Tel: +45 70 27 71 01  
info@oncollection.com  
www.oncollection.com

#### SHOWROOMS

Onecollection  
Showroom and office  
Frederiksgade 1  
DK-1265 København K

Onecollection  
Showroom  
Østergade 11  
DK-6950 Ringkøbing

Catalogue designed by:  
Anitta Falsig Laurberg & Morten Duemose

